



DV2000 *Digital Video* **VBI Encoder / Character Generator**

USER'S MANUAL

For Software Revision: 2.32

ULTECH Corporation

28 Great Hill Road, Bldg. #C, Seymour, CT 06483, USA

TEL: (203) 735-5805, FAX: (203) 735-6653, WEB: www.ultechvideo.com

WARRANTY

This product is warranted against defects in material and workmanship for a period of one year from date of shipment. During the warranty period, ULTECH Corporation will, at its option, either repair or replace defective products. For warranty service or repair, this product must be returned to a service facility designated by ULTECH Corp. Buyer shall prepay shipping charges for products returned to ULTECH for warranty service; ULTECH shall pay shipping charges to return product to the Buyer. Buyer shall pay all shipping charges, duties, and taxes for products returned to ULTECH from countries outside of the USA.

LIMITATION OF WARRANTY

The foregoing warranty shall not apply to defects resulting from improper use by Buyer. No other warranty is expressed or implied. ULTECH specifically disclaims the implied warranties of merchantability and fitness for a particular purpose. ULTECH shall not be liable for any direct, indirect, incidental or consequential damages resulting from the use of this product.

IMPORTANT

This instrument is an AC mains-operated electrical apparatus. Maintenance, repairs, and adjustments must be carried out only by qualified personnel. Do not operate the unit without the covers in place.

© ULTECH Corporation 1999

All rights reserved. Reproduction in any form is not permitted without written authority from the copyright owner.

Manual Publication No. PB100-DV2000, Rev. January 15, 1999

Printed in USA

Contents

1. General Information	5
1.1 Introduction	5
1.2 Closed Caption Encoder	6
1.3 Character Generator	7
2. Installation	9
2.1 How to connect	9
3. Operating Instructions	11
3.1 Front panel controls, indicators	11
3.2 Rear panel connections	12
3.3 Operating the DV2000	15
4. Front Panel Menus	17
4.1 Main Menu	17
4.2 Job Menu	18
4.3 CC Monitor Setup Menu	19
4.4 Time Code Offset Menu	19
4.5 Com 1 Setup Menu	20
4.6 Safe Title Area Menu	21
4.7 CC Level Setup Menu	22
4.8 CC Waveform Position Menu	23
4.9 EDH Error Detecting and Handling Status Menu	24
4.10 EDH Setup Menu	25
5. Script, Caption, and Subtitle Files	27
5.1 Introduction	27
5.2 Script Files	27
5.2 Caption Files	30
5.3 Subtitle Files	31
5.4 Graphics Files	32
5.5 UYC File Format	34
6. Technical Reference	41
6.1 Calibration	41
6.2 Pinouts	42
6.3 Disk Contents	44
6.4 Specifications	45

1. General Information

1.1 Introduction

Thank you for purchasing the DV2000—a versatile digital video platform for closed caption, text, and graphics generation. DV2000 is the industry’s first closed caption encoder and subtitle generator combined in a single unit. With it you can generate slates, bugs, TV rating icons and subtitles while encoding closed caption and XDS data. Post production and tape duplication facilities can perform these jobs in a single pass. Broadcasters can comply to FCC rules with a single unit by encoding closed captions and “V-chip” data while simultaneously displaying on-screen TV rating icons.

DV2000 is constructed in a modular fashion. All of the major components plug into industry standard slots. The modular architecture allows for easy repairs and upgrades in the field. There are slots available for options or for other functions that our industry may require in the future.

Easy Operation

A common complaint in the caption industry is that post houses and tape duplicators must deal with caption files with different formats and encoding requirements. DV2000 addresses this by reading all of the popular caption file formats. The encoder automatically determines the proper settings by looking at the data contained in the file—the operator doesn’t even have to specify the format.

DV2000 can read individual caption files, or it can read script files. A script file may contain instructions to display slates, logos, icons, etc. and it may also start a caption encoding session. Caption agencies may prepare script files that perform special tasks. Script files can automatically set DV2000 to the proper configuration to perform an encoding or subtitling job. ULTECH provides script templates which make it easy for caption agencies or supervisors to create custom scripts.

In a broadcast environment, DV2000 can act as a caption server. Caption data does not have to reside in the VBI of programs on videotape; it can be encoded “on-the-fly” as the program airs. Captions may be downloaded to DV2000’s hard disk via network or modem interface. A play list may be generated that instructs DV2000 to encode a sequence of shows based on time code. This technique saves a tape generation, plus it allows easier reformatting of captions if a show is edited.

1.2 Closed Caption Encoder

Caption encoding is where DV2000 truly excels. The heart of the encoder is the CCX caption encoding software module. CCX is ULTECH's PC-based closed caption encoding program. This program has been in use during the last three years in dozens of post production and duplication facilities. CCX has evolved into a stable and highly accurate method for metering captions based on time code. It ensures that captions will be revealed on the viewer's screen at exactly the moment intended by the caption's creator. We've taken our time-tested CCX software and modified it for use in the DV2000.

DV2000's most important feature is its ability to read caption files from the industry's leading agencies and caption software providers. Files from unsupported software vendors may be converted to ULTECH .ULT format and read directly. Of course, DV2000 may still encode captions the old fashion way—by sending data to a DV2000 serial port from a PC.

DV2000 can encode on any VBI line, in component or composite format, in NTSC or PAL. It can encode field 2 XDS data such as "V-chip" data while encoding captions in field 1. DV2000 has an upstream digital caption decoder, so it can reencode, pass, or merge data per EIA-608 recommendations. All of DV2000's encoding functions are performed in software-software that can be upgraded via ULTECH's web site. This ensures that DV2000 will stay current no matter what the industry may conjure up. Even DV2000's waveform generator is controlled via software. A benefit of this is that the caption waveform's "0 IRE" level and its "50 IRE" level may be set from the front panel or via script commands—no more problems with VTR's and converters that strip or add NTSC setup levels.

1.3 Character Generator

You may purchase DV2000 with an optional character generator to produce text and graphics on-screen. The CG option consists of a 2.5 GByte hard drive, 120 MByte LS-120 SuperDrive, 16 MByte video RAM module, faster CPU, and associated software. The CG provides two video frame stores of 24 bit RGB plus 8 bits of transparency (“alpha” channel). You can create any image in 16 million colors with 256 levels of transparency over the background video. Your image can occupy up to 512 TV scan lines in each frame. Although the DV2000 is not intended for special effects, it is possible to create simple animations with smooth motion—a rotating globe or a logo that grows, for example. A global fade function allows you to fade images on and off the screen independently from transparency settings.

How to create images with DV2000 CG

The DV2000 CG can display text and graphics based on low level “drawing” commands (the traditional method), or it can display text and graphics as individual “subpictures” (the modern method). In both cases, the commands and/or subpictures are received via a communications port, network interface, or local script file residing on disk. Commands and subpictures can be displayed by DV2000 based on longitudinal time code, GPI triggers, and internal or external timing.

In drawing mode, DV2000 provides the same commands found on ULTECH’s SG401 Subtitle/Character Generator. This mode is useful for repetitive display of text such as subtitling. Characters are rendered within the DV2000 in the specified font with the specified effects. In drawing mode, DV2000 uses the Unicode character set together with TrueType fonts. TrueType fonts may be downloaded through any communications port, or may be installed via disk. Version 2.26 Note: SG401 backward compatibility

In subpicture mode, DV2000 can display graphics images that are in .BMP, .PCX, .TIF, and .PNG formats. Subpictures are loaded into a non-displayed graphics buffer then displayed at the desired time. Subpictures are always rendered off-line, that is, on an external PC, Mac, or workstation. You can use any graphics drawing program to create subpictures including those from Adobe, Macromedia, MetaCreations, and many others. Subpictures can be wiped or faded on and off the screen.

Animation is accomplished by creating a series of individual frames—perhaps dozens—that represent the desired motion. The frames are downloaded to DV2000’s hard drive via a network interface or 120 MByte SuperDrive, then played in sequence. Animation packages such as MetaCreation’s Bryce3D render individual frames from key frames automatically.

2. Installation

2.1 How to connect

1. Apply source serial digital video to VIDEO IN connector. Source must be standard SMPTE 259M video. The DV2000 terminates the source video with 75 ohms.
2. Take the program video with encoded data/text & graphics from VIDEO OUT #1 or VIDEO OUT #2. VIDEO OUT #1 and #2 are serial digital outputs.
3. Connect VIDEO OUT #1 or #2 to Monitor Video In, a serial digital input.
4. Connect an analog composite video monitor to MONITOR VIDEO OUT or an S-video monitor to Y/C OUT (an S-video monitor is preferred). This output is used to monitor closed captions and to display on-screen menus when the DV2000 is in setup mode. This output is not intended to be used as a source of analog program video. If you need analog program video, it is recommended that you use a high quality serial digital-to-analog video converter at one of the DV2000 program video outputs.
5. Connect longitudinal time code to the LTC In connector via an XLR-to-Mini-DIN time code adapter cable (ULTECH part number OPT14). The LTC input can use either balanced or single-ended time code with a nominal level of +4 dBu.
6. Apply AC line power to the unit via the detachable three wire cord.

Grounding (earthing)

The DV2000 must be connected to a protective earth conductor via the three wire AC line (mains) cord. The AC power plug shall be inserted only into a receptacle outlet that has a protective earth contact. The ground wire must not be defeated by use of a two wire extension cord.



WARNING: Any interruption of the power line ground circuit inside or outside the DV2000, or removal of the AC receptacle ground wire, will create a potential shock hazard.

3. Operating Instructions

3.1 Front panel controls, indicators

- ❶ Power on/off switch.
- ❷ Reset. The DV2000 contains a reset button which is recessed inside the front panel. Pushing this button will cause the DV2000 to perform a power-on reset.
- ❸ Program Video LED. Illuminates when DV2000 detects proper incoming video.
- ❹ Monitor Video LED. Illuminates when DV2000 detects monitor video.
- ❺ Data In LED. Illuminates when DV2000 detects data at its RS-232, modem, or USB inputs.
- ❻ Time code LED. Illuminates when LTC time code is detected.
- ❼ Hard Disk LED. Illuminates when DV2000 reads or writes from its hard drive.
- ❽ Setup LED. The red Setup LED illuminates when you are in setup mode. In setup mode, on-screen menus are displayed on the decoder monitor.
- ❾ Floppy Drive. The DV2000 can read caption, subtitle, script, or graphics files via this drive. Also, DV2000 system software may be upgraded from this drive. DV2000's equipped with the optional character generator come with an LS-120 SuperDrive which can read 120 MByte disks as well as 3 1/2" 1.44 MByte disks.
- ❿ Cursor keys. Press ENTER to bring-up the on-screen menu. Press the left, right, up, down cursor keys together with the ENTER key to move through the menus and make selections.

Filter grill. The filter element should be washed or replaced every six months—sooner if your installation is particularly dusty.

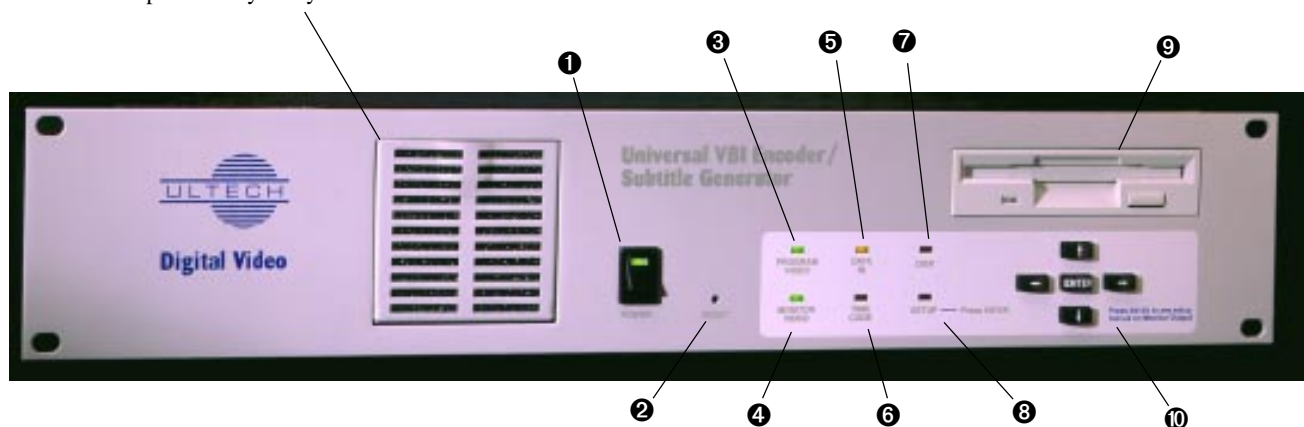

Fig. 3-1. Front panel

3.2 Rear panel connections

- ❶ Fan Grill. You must mount the DV2000 in a location that provides at least 6" of clearance behind this grill. Air is supplied through the front panel filter and discharged through the rear panel fan grill.
- ❷ IEC power output connector for detachable three wire AC line cord. Rated 120 VAC at 3A Max, or 240V at 2A Max.
- ❸ IEC power input connector for detachable three wire AC line cord.
- ❹ 120 VAC/240 VAC line voltage selection switch.

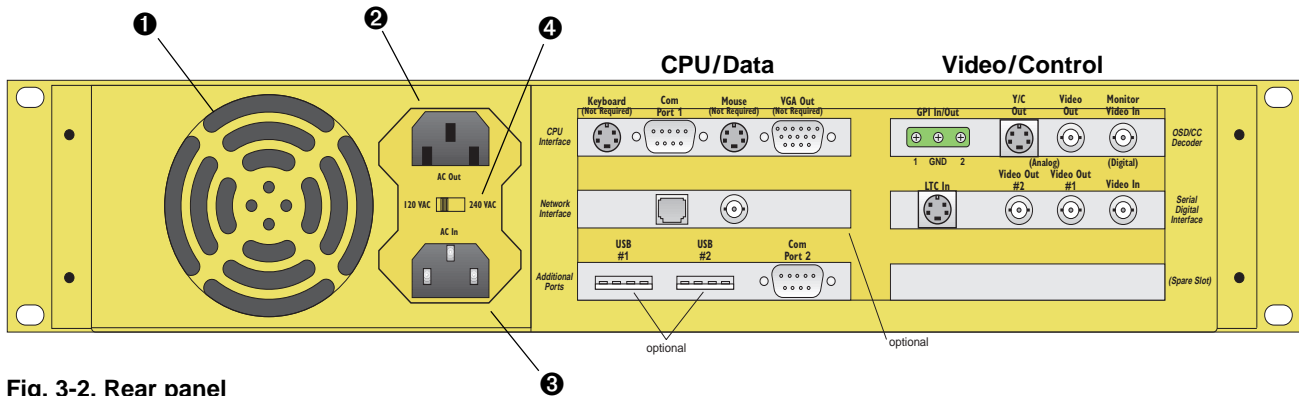

Fig. 3-2. Rear panel

CPU/Data Connections

- ❶ PS-2 style keyboard connector. You do not need to connect a keyboard for normal operation. You only need a keyboard for performing system upgrades or maintenance.
- ❷ Com 1 RS-232 serial interface connector.
- ❸ PS-2 style mouse connector. You do not need to connect a mouse for normal operation. You may optionally connect a mouse when performing system upgrades or maintenance.
- ❹ VGA output connector. You do not need a VGA monitor for normal operation. All on-screen menus and status screens appear at the VGA output. You need a VGA monitor when performing upgrades and maintenance.
- ❺ RJ-45 modular jack for unshielded twisted pair network cabling.
- ❻ BNC connector for thin coaxial network cabling.

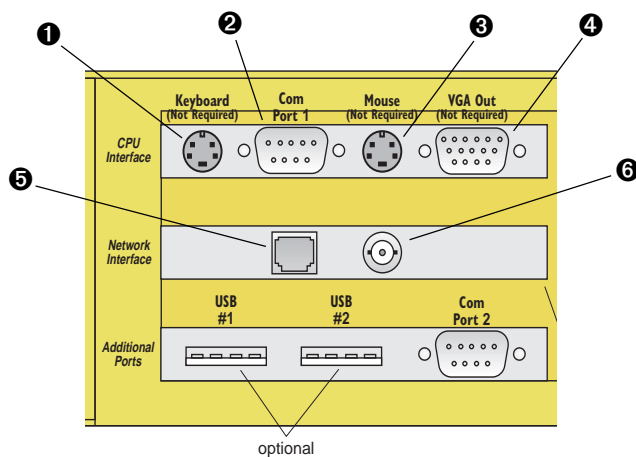

Fig. 3-3. CPU/Data connections

Video/Control Connections

- ❶ Serial digital video input. This input expects a standard SMPTE-259M component digital or composite digital signal, in either 525 or 625 standard. The input is internally terminated by 75 ohms.
- ❷ Serial digital program video output #1. This is a standard SMPTE-259M output with a 75 ohm source impedance. The output employs a controlled risetime cable driver circuit.
- ❸ Serial digital program video output #2. Identical to program video output #1.
- ❹ LTC time code input. This is a balanced longitudinal time code input that expects a nominal +4 dBu analog signal. A mini-DIN connector is used to save panel space. ULTECH option OPT 14 can adapt the LTC connector for use with a male XLR plug.
- ❺ Monitor video input. This is a SMPTE-259M serial *digital* video input that provides caption monitoring and on-screen menus. This input may be connected to DV2000 program video output #1 or #2, either through a short cable or via a serial digital router. Using a router gives you the option of monitoring closed captions from other serial digital video devices, such as a VTR. The input is terminated with 75 ohms.
- ❻ Monitor video output. This is a 1Vpp *analog* composite video output with a 75 ohm source impedance. This output contains an analog version of the program video with Captions/Text/XDS and CG overlaid. Also, the on-screen menus appear on this output as well. You can turn off caption monitoring as well as the on-screen menus. This output is not intended to be used as a high quality analog program output.
- ❼ Y/C monitor video output. This is an analog S-video output that delivers an analog version of the program video with captions, CG and on-screen menus overlaid.
- ❽ GPI port. This is a dual bidirectional GPI port. You can receive GPI triggers from external equipment, or you can program the DV2000 to generate GPI triggers and events. You respond to GPI triggers from within a program script. Likewise, you can generate GPI triggers from a script, perhaps based on certain time codes.

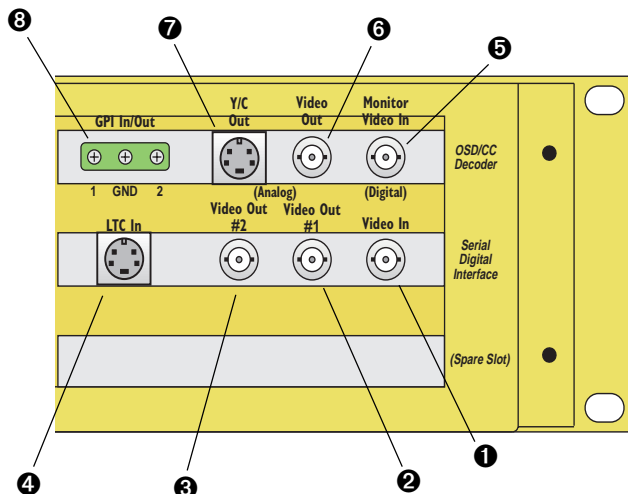

Fig. 3-4. Video/Control connections

3.3 Operating the DV2000

Power on

When power is first applied, the DV2000 will boot its operating system and will then run its DV2000 application program. This process takes about 15 seconds. After the application program has started, a DV2000 status screen will appear at the VGA output; nothing appears at the monitor output other than the video source which is connected to the monitor input.

Menus/cursor keys

Front panel control of the DV2000 is accomplished using the cursor keys and on-screen menus. The menus appear at the monitor output BNC and/or the VGA output. Pressing ENTER brings-up the main menu. Pressing the left and right arrow keys brings you to other menus. Pressing the up and down arrow keys allows you to scroll through choices within a menu. Pressing ENTER within a menu allows you to make changes to settings. Every menu screen has help messages to guide you.

Settings

Many aspects of the DV2000 may be customized by way of user *settings*. One example of a setting is *closed caption waveform amplitude*—the user has the ability to set the waveform to compensate for video sources that may, or may not, have 7.5 IRE pedestals added. Settings are made from the front panel, or they may be done via a script file, network, or serial port. Settings made from script files are active only while the script file is running. When the script finishes, settings revert back to the previous settings: the ones set from the front panel, network, or communications port. Settings may be “locked-out” from certain sources. For example, you may prevent the closed caption line to be changed from any source other than the front panel. You enable or disable settings in a command acceptance table that is accessed from the front panel.

The DV2000 stores all current settings on its hard drive in a file called “settings.cfg”. To restore factory default settings, simply delete or rename this file.

Over Temperature Alarm

DV2000 contains an over temperature alarm that produces a continuous beeping if the internal processor overheats. This could be caused by a dirty filter element, restricted air flow, or fan failure. Operating DV2000 in an over-temperature condition will result in erratic operation.

4. Front Panel Menus

4.1 Main Menu

DV2000 users typically deal with “jobs”, so the DV2000 menuing system is designed to handle jobs. A job may be a closed caption encoding session, or it may be a subtitle mastering session. Jobs are more natural for post production users than broadcast users. In post production, the DV2000 is used exclusively on a job by job basis. For example, in one day, a tape duplicator may encode closed captions for two movies, and create subtitles for a third. Each of these activities is considered a separate *job*. Broadcasters, on the other hand, may use the DV2000 for real-time closed caption encoding only. In that case, they may only have one “job” configured, and it may be named “Live Closed Captioning”.

The main menu is also referred to as the “jobs list” menu.

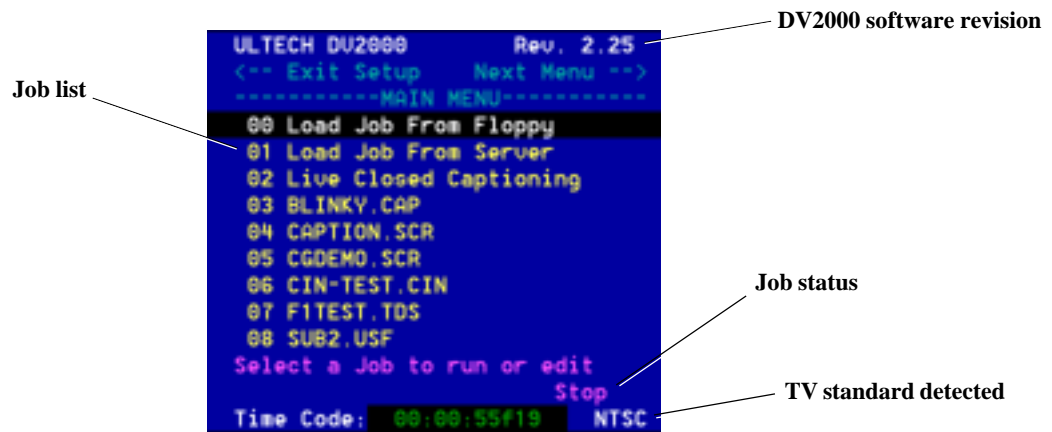

DV2000 has two “built-in” jobs: *Load Job From Floppy* and *Load Job From Server*. Other jobs that appear on the jobs menu are loaded by the user. When *Load Job From Floppy* is selected, files from a floppy disk (or 120 MByte SuperDisk) are copied into a unique subdirectory under the “jobs” directory on the DV2000 hard drive. Only script, caption, subtitle, and graphics files are copied; all other files are ignored.

If the job consists of a single caption file when loaded, the menu changes to that specific caption job and the job is run automatically. This means an operator has only to insert a floppy disk into the drive and select *Load Job From Floppy* to run an encoding job.

The DV2000 allows you to change certain parameters associated with closed captioning, such as waveform amplitude and time code offset. When a caption job is run as described above, the front panel settings are in effect. A user may create a script file that changes some of the settings, then executes the caption job. In that case, the script file settings are used.

4.2 Job Menu

The job menu allows you to work with a particular job. You can run the job, cancel the job (if it is already running), save it as another name, or delete the job. Each job resides in its own subdirectory under *dv2000\jobs*. The directory has the same name as the main job file. For example, if you load a closed caption job from the floppy or network server that contains a single file “Blinky.cap”, a directory called “Blinky” is made: *dv2000\jobs\Blinky*. The directory *Blinky* contains the file *Blinky.cap*. If you load a subtitle file called “Movie1.usf” and associated bit map files, a directory called “Movie1” is made: *dv2000\jobs\Movie1*. The directory contains the file *Movie1.usf* plus all of the subtitle image files.

When you delete a job from the hard drive, all of the files contained in the job’s subdirectory are erased, and the subdirectory is removed.

```
ULTECH DV2000 Rev. 2.30
<-- Main Menu
002 BLINKY.CAP
-----JOB MENU-----
Run job
Cancel job
Save job as
Delete job

Run Selected Job
(NOTE - DV2000 can only run
one job at a time.)

Time Code: 00:00:37f29 Stop NTSC
```

4.3 CC Monitor Setup Menu

The monitor menu lets you determine which line 21 data service to monitor at the analog monitor output connector. You can choose field 1 services: CC1, CC2, T1, T2, or you can choose field 2 services: CC3, CC4, T3, T4, XDS (Extended Data Services). Press ENTER to cycle through the choices.

TIP: Choose a Text service (T1-T3) as a quick check for the presence of a closed caption waveform—you will get a black box that nearly fills the monitor screen if a line 21 waveform is present.



4.4 Time Code Offset Menu

DV2000 contains an internal LTC time code reader. When an off-line closed caption or subtitle job is run, captions/subtitles are processed when time code read from the LTC input port matches time code from the caption/subtitle file. The timing for caption/subtitle files is established from the time code provided to the caption agency. But when the job is run, the time code accompanying the program video may have changed. The time code offset menu lets you adjust time code read by the internal time code reader in increments of +/- 1 frame. The time code offset is added to the time read by the internal LTC reader. The time code displayed in the on-screen menu reflects the sum of incoming time code and the offset.

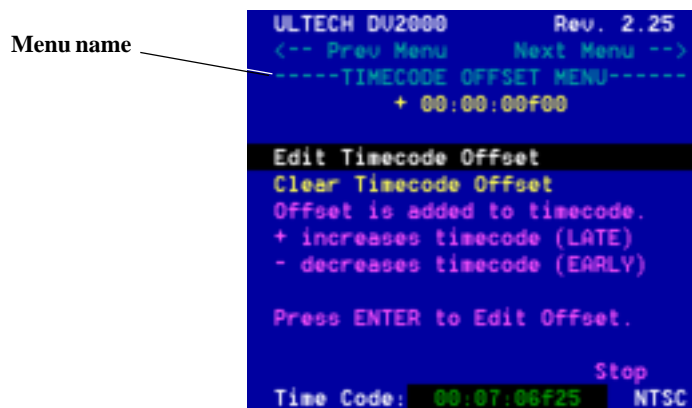

Important Note: Caption creators go to extreme lengths when timing captions. You should discuss changes in time code with the agency that provided the captions/subtitles before offsetting time code.

4.5 Com 1 Setup Menu

This menu lets you set-up the DV2000 to receive closed caption data via its Com1 RS-232 serial interface. There are two cases where you may want to send data via the serial port: 1). For live or real-time captioning, 2). To encode line 21 data from off-line service providers that will not allow ULTECH to encode their data from floppy disk. Wherever possible, DV2000 users should choose service providers/applications software that provide data as files that are read directly by DV2000. This eliminates the requirement of having a stand-alone PC drive the DV2000 via the serial port.



```
ULTECH DV2000          Rev. 2.26
<-- Prev Menu      Next Menu -->
-----SETUP COM 1 MENU-----

Function  ICAP EMULATION
Baud Rate 9600
Format    8N1

UP/DOWN to change selection.
ENTER to change COM1 function.

                                Stop
Time Code: 00:00:31F20  NTSC
```

In an effort to support existing software, ULTECH will provide several “emulation” modes for line 21 encoding via the DV2000 serial port. The current version of DV2000 software provides compatibility with the ULTECH *Insertacap*. This mode offers both field 1 and field 2 encoding for Captions, Text, and XDS Extended Data Services. You may obtain a programmer’s reference by contacting ULTECH. Nearly every real-time and off-line application can be handled in *Insertacap emulation mode*. In the near future, ULTECH will provide an emulation mode for the EDS400 Encoder. Among other things, this will allow the merging of TV Crossover Links with upstream data, and the merging of locally inserted XDS data with upstream data.

In this menu, you can set the baud rate to 1200, 9600, 19.2K, 38.4K, 57.6K, and 115.2K bits per second. You can also choose between 8 data bits, no parity, 1 stop bit, or 7 data bits, odd parity, 1 stop bit. Please consult your applications software manual for the preferred settings.

4.7 CC Level Setup Menu

DV2000 allows you to adjust the “data bit low” level and “data bit high” level of the encoded closed caption waveform. Normally, the adjustment is made such that data bit low produces a 0 IRE level, and data bit high produces a 50 IRE level. In an analog encoder, these adjustments are usually made with a trim pot. In the DV2000 digital encoder, the adjustments are made by specifying a numeric value, either from the front panel or via a script command.

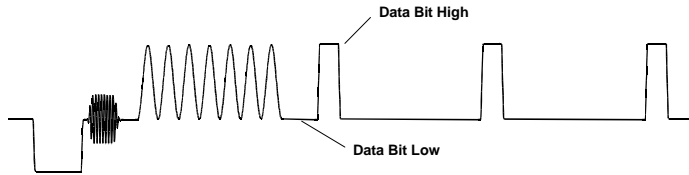

SMPTE 125M specifies the assignment of luminance values as 877 quantization levels with black level corresponding to level 64 and the peak white level corresponding to level 940.

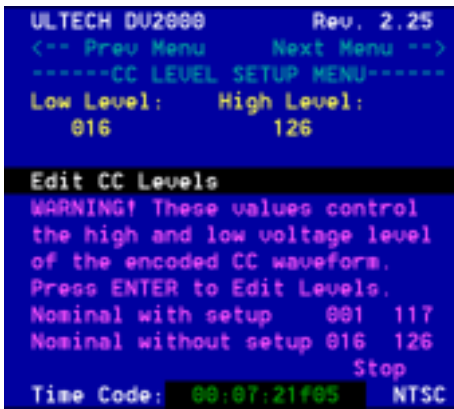

	IRE	10 bit	8 bit *
Reserved to indicate TRS	-	0 (000H)	0 (00H)
Black Level	7.5	64 (040H)	16 (10H)
White Level	100	940 (3ACH)	235 (EBH)
Reserved to indicate TRS	-	1023 (3FFH)	255 (FFH)

* The DV2000 waveform generator uses 8 bit values

The spec fails to address the levels used by VBI services such as Closed Captioning and NABTS teletext which are referenced to blanking level (0 IRE). So the industry has responded with two solutions. The first solution is to change the slope of the DAC during the VBI so that the value of 16 corresponds to 0 IRE and the value of 235 corresponds to 100 IRE. This is usually termed “no 7.5 IRE setup” or “without setup”. The second solution is to use the values 1-15 to generate the IRE values below the value of 16 (7.5 IRE). An IRE value of zero is not possible because zero is reserved for TRS indication. This is usually termed “with 7.5 IRE setup” or “with setup”.

The existence of both solutions in the field complicates the task of inserting VBI waveforms into D1 video. The DV2000 solves this problem by allowing the user to set the min and max values used to generate closed captioning waveforms.

8 bit D1 value	IRE with setup	IRE without setup	
1	1.16	-	↔ nominal min with setup
2	1.59	-	
3	2.01	-	
15	7.08	-	
16	7.50	0.00	↔ nominal min w/o setup
17	7.92	0.46	
116	49.74	45.66	
117	50.16	46.12	↔ nominal max with setup
118	50.58	46.58	
125	53.54	49.77	
126	53.96	50.22	↔ nominal max w/o setup
127	54.38	50.68	
235	100.00	100.00	

Table 4.1 IRE vs. D1 Level

4.9 EDH Error Detecting and Handling Status Menu

A recommended practice exists that allows you to detect serial digital transmission errors as well as errors in digital video equipment. The practice is known as SMPTE RP 165 *Error Detection and Handling System*. The DV2000 fully supports this recommended practice by providing two EDH processors: one to detect errors in upstream equipment, and one to recompute checksums for the benefit of downstream equipment. The system works by computing and transmitting checksums separately for full field data, for active picture data, and for ancillary data. The DV2000 computes the checksum for the incoming data and compares it against the transmitted checksum. If they deviate then an error flag is set in the EDH Status Menu. A flag is set according to the nature of the error.

```

ULTECH DV2000          Rev. 2.25
<-- Prev Menu      Next Menu -->
-----EDH STATUS MENU-----
                EDH EDA IDH IDA UES
Full Field      ok  ok  ok  ok  ok
Active Pic     ok  ok  ok  ok  ok
Ancillary      ok  ok  ok  ok  ok
Packet Checksum: ok
Error Count: 0
Update Error Status
Clear Errors and Error Counter
Update EDH Error Status Display
                                Stop
Time Code: 00:07:41f16 NTSC

```

The following is an explanation of possible errors:

EDH *Error Detected Here*

If the incoming checkword does not match the calculated checkword, the EDH flag is set.

EDA *Error Detected Already*

If the incoming EDH flag is set and the EDA flag has not been set, the EDH flag will be cleared and the EDA flag will be set. However, if the incoming checkword is invalid then the outgoing EDA flag will be set according to the incoming EDA flag only.

IDH *Internal Device Error Detected Here*

These flags would normally be set by the DV2000 to detect internal failures. The current DV2000 software version does not set these flags.

IDA *Internal Device Error Detected Already*

This flag is passed from input to output by the DV2000. The DV2000 ignores this flag, although you can view the flag in the EDS Status Menu.

UES *Unknown Error Status*

This flag is passed from input to output by the DV2000. The DV2000 ignores this flag, although you can view the flag in the EDS Status Menu. This bit is also set if the incoming data does not have an error data packet. This informs downstream SDI devices that the data being sent by the DV2000 has not been checked for errors.

Other menu items:

Packet Checksum This is the latest full field checksum. The checksum, together with the error flags may be refreshed by selecting "Update Error Status".

Error Count Counts the number of fields that had errors. This counter will accumulate errors until you reset it by selecting "Clear Errors and Error Counter", or until a count of 2 million is reached.

5. Script, Caption, and Subtitle Files

5.1 Introduction

The DV2000 is able to read and encode closed caption files in a number of formats. Likewise, it can read subtitle files and associated “bit mapped” image files to produce open subtitles. When reading a caption or subtitle file, the DV2000 processes each caption or subtitle single-mindedly until the file ends. Although this mode of operation is fine for simple captioning and subtitling jobs, the full potential of DV2000 is realized using *script* files.

5.2 Script Files

DV2000 VBI Encoder/Subtitle Generator may be controlled by command sequences stored in script files. Script files may be loaded from the DV2000 floppy drive, or they may enter via any of the communications ports including the modem and local area network port. Scripts may be created and edited using a text editor such as Microsoft Notepad. ULTECH provides script templates for many different applications. The templates contain default settings for all of the changeable parameters. In the near future, ULTECH will offer a Windows program that makes it easy to create and test scripts.

DV2000 scripts contain sections for setting up closed captioning, teletext, Audio-in-VBI, and the character generator. These sections correspond to DV2000 on-screen menus. The body of the script may contain commands to display text and graphics. The script may also contain commands to encode line 21 data such as closed captions and XDS. When a script is loaded, the user can scroll through the menus in order to verify settings. The user can also change settings, although some are awkward using just cursor keys (such as XDS fields with long names). DV2000 scripts have a file extension of “.uxf”. In section 5.3, you will read about another script file format that is optimized for subtitle applications.

Details of Script Language

A script file is an ASCII text file that contains lines of commands. There are three categories of commands:

- 1). *Script Control Commands* which control the sequencing of the script files.
- 2). *Caption Commands* which affect DV2000 caption settings or generate closed caption/text/XDS data.
- 3). *CG Commands* which affect character generator settings or generate text/graphics on screen.

Only one command per line is allowed with a maximum of 132 characters per line. Script commands are case insensitive and leading spaces are allowed. Any text separated by a delimiter following a script command on the same line is considered a comment and is ignored except with the MSG command where the entire line following the command is used as a message.

Numeric command arguments can be entered in decimal or hexadecimal. A \$ must prefix a hexadecimal number if used as a numeric command argument.

Valid delimiters - {space} {;} {,} {=} and are denoted by |

Script Control Commands

Delay|n n=[0..65535]

The Delay command waits for n milliseconds before further script commands will execute.

Msg|string string=[1..70 characters]

The Msg command displays a string in the osd window of the DV2000's monitor output. It is useful for cueing and aiding the DV2000 operator.

Example Msg This is a message

Pause

The Pause command waits for a front panel key or key press on the optional keyboard to be pressed before further script commands will execute. The message 'Press any key to continue...' will be displayed on the monitor output.

Rem|string string=[1..70 characters]

The Rem command is used for inserting comment lines into a script file. All characters following the Rem command will be ignored. This command is useful for displaying messages on the screen and adding comments to lines that contain no other commands.

Rerun

Reruns the script file from the beginning.

Script|filename filename must conform to MS-DOS file naming conventions.

The Script command is used to pass control over to another script file. The extent of Control passing is unlimited.

Example Script c:\test\test1.uxf

SetTime|n n=H:M:S:F

Establishes an arbitrary starting time when using simulated time code.

WaitUntil|n n=H:M:S:F

Wait until the time code is greater than or equal to H:M:S:F before further script commands are executed. Time code is either read externally or is simulated with the DV2000's internal clock. If you are using simulated time code then you must precede the first WaitUntil command with a SetTime command.

LoadYCrCb|X Y filename (only works if CG option installed)

Loads a YCrCb bitmap image to the non-displayed memory at location (X,Y). Location X,Y is with respect to the top-left corner of the screen. The bitmap image is in Y Cr Cb format. ULTECH provides a conversion program to convert from PCX and BMP to Y Cr Cb.

Flip (only works if CG option installed)

Flips frame buffer memories. The DV2000 contains two video frame buffers: one is considered the "displayed" memory, and the other the "non-displayed" memory. The Flip command causes the displayed memory to become the non-displayed memory and vice versa.

FlipE (only works if CG option installed)

Same as Flip but also erases the non-displayed memory.

EraseDmem (only works if CG option installed)

Erases the displayed frame buffer memory.

EraseNDmem (only works if CG option installed)

Erases the non-displayed frame buffer memory.

EncodeCC|filename

Starts a closed caption encoding session. The caption data file specified by *filename* must be in Captions Inc. ".cin", NCI ".cap", Caption Center ".tds", or ULTECH ".ult" format. The DV2000 will automatically determine which format is supplied by reading the file. Once started, the caption encoding job will run concurrently with subsequent DV2000 commands. The caption job will run until it is completed or the script file is aborted.

End

Marks the end of the script file.

5.2 Caption Files

Currently, DV2000 can read caption files in the following formats:

<u>Provider</u>	<u>File Extension</u>
Captions Inc.	.CIN
National Captioning Institute	.CAP
The Caption Center	.TDS
ULTECH	.ULT

The caption files may be loaded into the DV2000 via the front panel floppy drive, network interface, modem, or serial port.

The ULTECH caption file format (ULT file) is a compact binary file that stores captions with embedded EIA-608 control codes and time code data. It was designed as a fast intermediate file format for CCX and the DV2000, not for general purpose caption creation. As a result it is *not* readable by a text editor. CCX is ULTECH's Windows-based encoding software that is used to drive analog encoders and character generators manufactured by ULTECH.

Note: The .ULT file must contain captions that have the appropriate control codes embedded with the text. Also the time code for each caption should be equal to the desired appear time. DV2000 does not adjust the caption appear time.

The .ULT file format supports multi-stream captions. Multi-stream captions allow multiple data channels to be encoded at the same time. For example, bilingual captioning: English on CC1 and Spanish on CC2.

A software development kit is available from ULTECH that includes a full specification for the .ULT format together with sample source code and data files.

5.3 Subtitle Files

There are two ways for character generators to display text on screen. The “traditional” method involves sending commands and text to the character generator by way of a serial communications port. The CG interprets the commands and turns the text strings into on-screen characters. The CG renders the characters in real time based on attributes you have specified, such as color, font, and position. A future version of DV2000 software will provide this capability—the command set will be backwards compatible with ULTECH’s SG401 analog subtitle/character generator.

A more modern way of generating text on screen is to create the subtitles off-line in the form of bit-mapped images. Each subtitle becomes an individual bit-mapped image file. The advantage of this approach is that the CG does not have to deal with fonts, nor does it have to deal with rules involving the conversion of commands and text strings into on-screen characters. With this method, subtitles are created on a PC using any font installed on the PC. You can see on the PC’s monitor how the subtitle will look when displayed on a TV screen.

Subtitling using the bit-mapped method involves two sets of files: a single subtitle “script” file and a series of bit-mapped files, one for each subtitle. In the DVD world, subtitle script files are known as “navigation” files. The DV2000 uses a simple file format that is optimized for subtitling. Files in this format have a file extension of “.usf”, and are therefore referred to as “USF” files, or simply “subtitle files”.

.USF File Format

ULTECH subtitle script files contain a single command, *subtitle*. The command takes the parameters *time code*, and optionally, *filename*, *x position* and *y position*. The first parameter is the time that the file is to appear on the display. If the filename is omitted, then the display is *erased* at the time code. Thus a subtitle command with a time code and a filename means “display this graphic file at time *t* at position *x,y*”; and a subtitle command with only a time code means “erase whatever is on the display at time *t*”. Note: The commands should appear in chronological order in the file.

Example:

```
SUBTITLE 00:01:00:09 nine.uyc 0 0
SUBTITLE 00:01:00:10 ten.uyc 0 0
SUBTITLE 00:01:00:11
```

This example displays the bitmap *nine.uyc* in position 0,0 at time code one hour and nine seconds, at time code one hour and ten seconds *ten.uyc* is displayed, and finally at one hour and eleven seconds the display is erased. This specialized command makes the creation and reading of subtitle files easy and intuitive.

The subtitle application reads bit mapped graphics files in ULTECH’s “.uyc” format. The following section discusses this format in detail.

5.4 Graphics Files

DV2000 displays bit mapped graphics files in a format known as “YCrCb”. YCrCb is the component video format inherent in serial digital video. ULTECH created a YCrCb file format known as “YC” format. Section 5.5 provides details about this file format. Software developers may choose to produce graphics files directly in YC format. Other DV2000 users may create files in several industry formats, then convert them to YC format. A future version of DV2000 software will convert all of the popular formats to YC format as the files are transferred to the DV2000. The current version of software requires a separate conversion step on a PC using graphics file converters supplied by ULTECH. ULTECH provides a Microsoft Windows program that lets you view YC files on a PC without requiring DV2000 hardware.

Graphics Files Supported

All of the files described in this section are comprised of Red, Green, and Blue color components (“RGB”). Combinations of RGB are mixed to produce all of the colors possible on a TV screen. The 8 bit RGB formats—the formats where RGB can each be 1 of 256 possible values—produce over 16 million colors. Not all can be conveyed with serial digital component video, though, as component video yields a color space that is a subset of RGB colors (11,137,500 colors out of 16,777,216).

Some of the formats below employ an “alpha” channel in addition to RGB channels. An alpha channel specifies transparency. Each pixel is made up of a Red, Green, and Blue component. Plus, there is an alpha component that specifies the *opacity* of the pixel. An alpha value of “0” means the pixel is transparent: only background video is seen. An alpha value of “256” means the pixel is 100% opaque. Values in between allow background video to mix with foreground text/graphics. The DV2000 provides an 8 bit alpha capability. Use of an alpha gradient between foreground images and background video is one of the secrets for producing perfect images on screen.

BMP Version 4

This is Microsoft’s BMP format released for Windows 95, and is a 32 bit format containing 8 bits each of red, green, and blue, plus an 8 bit alpha channel. ULTECH supports the non-compressed, 32 bits per pixel version of this format. Use the file converter “BMP.EXE” to convert these files to ULTECH’s “YC” format.

PCX

PCX, also known as PC Paintbrush Format, is a popular graphics file format. PCX does not provide an alpha channel. ULTECH supports the 24 bit format. Use the file converter “PCX.EXE” to convert these files to ULTECH’s “YC” format. Because PCX does not support alpha, the converter generates a fully opaque image in YC format.

PNG

PNG, pronounced “ping”, is the format recommended by ULTECH for use with the DV2000. PNG files are compressed, so they require less disk space than the other formats. Plus, PNG offers a full alpha channel. Unlike 32 bit BMP, PNG files are handled by Adobe Photoshop, a leading graphics creation and editing program for the Mac and PC. Use the file converter “PNG.EXE” to convert PNG files to ULTECH’s “YC” format. ULTECH’s converter supports true color + alpha (type 6) PNG files (RGB + alpha).

TIFF

The TIFF format is important as one of its variants seems to be the format of choice for DVD subtitles. The ULTECH TIFF converter handles non-compressed 256 color “color map” type TIFF files in single or multiple strips. Like PCX, TIFF does not support alpha, so the converter considers the first entry in the color palette to be the transparent “color”; all other entries in the palette are opaque colors. Use the file converter “TIFF.EXE” to convert these files to “YC” format.

DVD TIFF files come in two formats: *full size* and *cropped*. A full size TIFF file occupies the entire 720 x 480 pixel plane, regardless of how big the actual subtitle is. A cropped TIFF file is just large enough to hold the subtitle image. For example, a cropped TIFF file may be 260 pixels wide by 80 pixels high. Full size TIFF files are normally very wasteful of disk space, and may require more time to transmit, load, and render on screen. Because of this, ULTECH has created a compressed version of the “YC” format that drastically reduces file size and load time. This format has the extension “UYC”. Use the file converter “Tiff2UYC.EXE” to convert files to compressed “UYC” format.

YC File Viewer

ULTECH provides a utility program that enables you to view YC graphics files on a PC. This allows users and software developers to inspect files without the need for DV2000 hardware. The program is called “ViewYC.exe” and runs under Microsoft Windows. ViewYC lets you view foreground RGB colors independently from the alpha channel. Likewise, there is a viewer called ViewUYC.exe that lets you view compressed UYC files.

5.5 UYC File Format

Digital Video (SMPTE 125M—4:2:2 Component) information consists of luminance (Y) and color difference (CR & CB) values. For each line of active video there are 720 luminance values and 360 pairs of color difference values. The information for each line is transmitted in the following order:

CB0, Y0, CR0, Y1, CB1, Y2, CR1, Y3, CB359, Y718, CR359, Y719

DV2000 groups this information into “pixel pairs”. The first pixel pair of a line consists of the Y values for both pixels (Y0 & Y1) and the CB & CR values for the pixel pair (CB0 & CR0). The values are each 8 bits and are organized into two 16 bit words (Y0 is the least significant byte of the Y word and CB0 is the least significant byte of the C word). Alpha information is also used by DV2000 to control the opacity of the overlaid graphics. An 8 bit alpha value is assigned to each pixel and organized into a third 16 bit word (alpha0 is the least significant byte of the alpha word and aligns with the same pixel as Y0). There are 256 levels of opacity for each pixel. An alpha value of zero is transparent, so the pixel will be 100% background video. An alpha value of 255 is opaque, so the pixel will be 100% overlay. All of the values in between select levels of semi-transparency for the pixel.

The information for each pixel pair consists of 1 word of Y values, 1 word of color difference values, and 1 word of alpha values.

Image Positioning

When DV2000 inserts an image (UYC file) into the video, it must know where on the screen to position the image. So, the DV2000 command to display an image requires three parameters: the UYC file name, an X offset, and a Y offset.

The X offset parameter specifies how much to offset the left edge of the image from the left edge of the television screen. Since the DV2000 handles all image data in pixel pair format, the X offset parameter value can only be between 0 and 360. If the X offset is zero then the left edge of the image will align with the left edge of the television screen. If the X offset is 180 then the left edge of the image will be in the middle of the television screen.

The Y offset parameter specifies which video line will contain the first line of the image. Video lines are numbered 1 to 262 for NTSC (1 to 313 for PAL) for each video field with line 1 at the top. Note that video lines 1 to 20 are defined as the vertical blanking interval (VBI) and are not displayed on the television screen. Also, line 21 (22 for PAL) is used for the closed caption waveform. Because of this, the first displayed video line overlaid by the DV2000 CG is line 23 (lines 1 to 22 are overlaid by the VBI waveform generator and lines 23 to 262 are overlaid by the character generator). Since the DV2000 performs image processing on a field by field basis, the Y offset parameter can only be between 23 and 262 inclusive for NTSC (40 - 295 for PAL). If the Y offset is 23 (in NTSC) then the top edge of the image will align with the top edge of the television screen. If the Y offset is 142 then the top edge of the image will be in the middle of the television screen.

X offset = Number of pixel *pairs* between left edge of image and left edge of television screen. Valid values are 0 to 360.

Yoffset = Video line number (of odd field) of the top edge of the image. Valid values are 23 to 262 for NTSC and 40 to 295 for PAL.

The discussion talks about alignment with respect to a television “screen”. This, of course,

does not take into consideration the fact that the image raster on televisions is overscanned. So a portion of the image will be “cut-off” if it is placed at the very edges of the image raster. DV2000 has a built-in safe title area generator to help you locate images in a location that will be visible on consumer television sets.

Details of the UYC File Format

All data contained in a UYC file is organized into words (unsigned 16 bit) with the low (least significant) byte first (Intel format). The first 16 entries (words) in a UYC file is defined as the header section. The header section contains image information such as width, height, etc. The remainder of the file is the image data section, and it contains three words of image data for each pixel pair (see introduction). The image data is arranged into lines to facilitate faster transfer to the DV2000. Each line of image data consists of a line of Y data, a line of C data, and a line of alpha data.

Header Section

<u>Word</u>	<u>Description</u>	<u>Value</u>
0	Signature 0	0x5955 (“YU”)
1	Signature 1	0x2043 (“ C”)
2	Version	0x0100 (1.00)
3	X size (image width)	0-0x02D0 (0-720)
4	Y size (image height)	0-0x0200 (0-512)
5	Compression type	0-1
6 - 15	Reserved for future use	(always zero)

Signature 0, 1 These two words are used by the DV2000 to indicate that this file is a UYC file. The words are arranged so that when a UYC file is viewed with a hex editor the first four bytes appear as “UYC<space>”.

Version This entry indicates the version of the UYC file.

X Size This entry indicates the width of the image in pixels. NOTE that this parameter MUST be an even number to conform to the pixel pair organization described in the introduction.

Y Size This entry indicates the height of the image in pixels (or lines). NOTE that the DV2000 can display up to 479 lines of image data in NTSC format and up to 512 lines of image data in PAL format (see DV2000 Image Positioning).

Compression This entry indicates if the image data has been compressed and which type of compression was used. Currently the only valid values are 0 for no compression and 1 for RLE compression (see UYC RLE Compression).

Note that X size must be even to conform to word boundaries. Graphic file converters, when converting a file with an odd width, should add a column of pixels to the right side of the picture and set the alpha values for these pixels to 0 (transparent).

Image Data Section of a UYC File

The image data section contains all of the Y, C, and alpha data (see *Converting RGB to YCRCB* that follows). The origin of the DV2000 coordinate system is the upper left (line 0 is at the top and pixel 0 is at the left edge). The image data is arranged into lines to facilitate faster transfer to the DV2000. Each line of image data consists of a line of Y data, a line of C data, and a line of alpha data. The order of the lines of data is dependent on the type of compression.

For uncompressed UYC files (compression = 0) the line of Y data is written first, then the line of C data, then the line of alpha data. The following pseudo code illustrates how to write an uncompressed UYC file.

```
write the file header
for L = 0 to (Y size - 1)
  for P = 0 to ((X size/2) - 1)
    write the Y data for line L and pixel pair P
  next P
  for P = 0 to ((X size/2) - 1)
    write the C data for line L and pixel pair P
  next P
  for P = 0 to ((X size/2) - 1)
    write the alpha data for line L and pixel pair P
  next P
next L
```

For compressed UYC files (compression != 0) the line of alpha data is written first, then the line of Y data, then the line of C data. Also each line of alpha, Y, and C data is compressed to reduce file size (see Appendix B - UYC RLE Compression). For simplicity, the compression is only applied to one line of data at a time so that the decompression algorithm doesn't have to find the boundaries between each line of compressed data. The following pseudo code illustrates how to write a compressed UYC file.

```
write the file header
for L = 0 to (Y size - 1)
  compress the line of alpha data for line L
  write the compressed line of alpha data
  compress the line of Y data for line L
  write the compressed line of Y data
  compress the line of C data for line L
  write the compressed line of C data
next L
```

Converting RGB to YCRCB

The following pseudo code illustrates how to convert RGB image information into YCRCB image information.

GREEN, BLUE, Yvalue, Cvalue, and Avalue are 8 bit unsigned values,

Yhi, Ylo, Chi, Clo, Ahi, and Alo are 8 bit unsigned values,

R0, G0, B0, A0, R1, G1, B1, and A1 are floating point values,

AVGR, AVGG, and AVGB are floating point values,

Y0, Y1, CR, and CB are floating point values,

Yarray, Carray, and Aarray are arrays of 16 bit unsigned values.

for L = 0 to (Y size - 1)

 for P = 0 to (Xsize - 1) step 2

 get RED, GREEN, BLUE. and alpha value for line L, pixel P

 R0 = RED / 255 (floating point value between 0 and 1)

 G0 = GREEN / 255 (floating point value between 0 and 1)

 B0 = BLUE / 255 (floating point value between 0 and 1)

 if (X size is odd) and (P = (Xsize - 1)) then

 R1 = R0 (if image width is odd then make the

 G1 = G0 image width even by adding a

 B1 = B0 transparent pixel at the end of each line)

 A1 = 0

 else

 get RED, GREEN, BLUE. and alpha value for line L, pixel P+1

 R1 = RED / 255 (floating point value between 0 and 1)

 G1 = GREEN / 255 (floating point value between 0 and 1)

 B1 = BLUE / 255 (floating point value between 0 and 1)

 end if

 AVGR = (R0 + R1) / 2 (compute average color of pixel pair)

 AVGG = (G0 + G1) / 2

 AVGB = (B0 + B1) / 2

 Y0 = 0.299 R0 + 0.587 G0 + 0.114 B0

 Y1 = 0.299 R1 + 0.587 G1 + 0.114 B1

 CR = 2 * (0.500 AVGR - 0.419 AVGG - 0.081 AVGB)

 CB = 2 * (0.500 AVGB - 0.169 AVGR - 0.331 AVGG)

$Y_{lo} = (Y0 * 219) + 16$ (final value 16 - 235)
 $Y_{hi} = (Y1 * 219) + 16$ (final value 16 - 235)
 $C_{lo} = (CB * 112) + 128$ (final value 16 - 240 centered around 128)
 $C_{hi} = (CR * 112) + 128$ (final value 16 - 240 centered around 128)
 $A_{lo} = A0$ (value = 0 to 255)
 $A_{hi} = A1$ (value = 0 to 255)

put Y_{lo} and Y_{hi} into Yarray for line L and pixel P/2

put C_{lo} and C_{hi} into Carray for line L and pixel P/2

put A_{lo} and A_{hi} into Aarray for line L and pixel P/2

next P

next L

UYC Compression

The UYC RLE (Run Length Encoding) compression is used to compress lines of alpha, Y, and C data. The compression is applied to only one line of one type of data (alpha, Y, or C) at a time. The RLE compression converts runs of the same value to a three word vector. The first word is the vector indicator value (0x0FF1). The next word after the vector indicator value is the run count, and the third word is the run value.

<u>Word</u>	<u>Description</u>	<u>Value</u>
0	Vector Indicator	0x0FF1
1	Run Count	2 - 360
2	Run Value	0x0000-0xFFFF

Run Vector Insertion Rules

1. If a single instance of the vector indicator value (0x0FF1) appears in the data being compressed then it is duplicated.
2. If a run of two or more instances of the vector indicator (0x0FF1) appears in the data being compressed then a run vector is inserted indicating the count (run length) and the value (in this case 0x0FF1).
3. If a run of three or more instances of the same value appears in the data then a run vector is inserted indicating the count (run length) and the value.

The following pseudo code illustrates how to compress a line of data. The data can be a line of alpha, Y, or C data in an array.

```

array is an array of 16 bit unsigned values (alpha, Y, or C values)
value, last_value, and count are 16 bit unsigned values
value = first element of array
count = 1

for P = 1 to ((Xsize/2) - 1)
    last_value = value
    value = next element of array
    if (value = last value) then increment count
    if (value != last value) or (at end of array) then
        if (count = 1) then
            output last_value
            if (value = 0x0FF1) then output last_value again
            if (at end of array) then
                output value
                if (value = 0x0FF1) then output value again
            else
                if (count = 2) and (last_value != 0x0FF1) then
                    output last_value twice
                else
                    output vector (0x0FF1, count, last_value)
                end if
            if (at end of array) and (value != last_value) then
                output value
                if (value = 0x0FF1) then output value again
            end if
        end if
    end if
    count = 1
end P

```

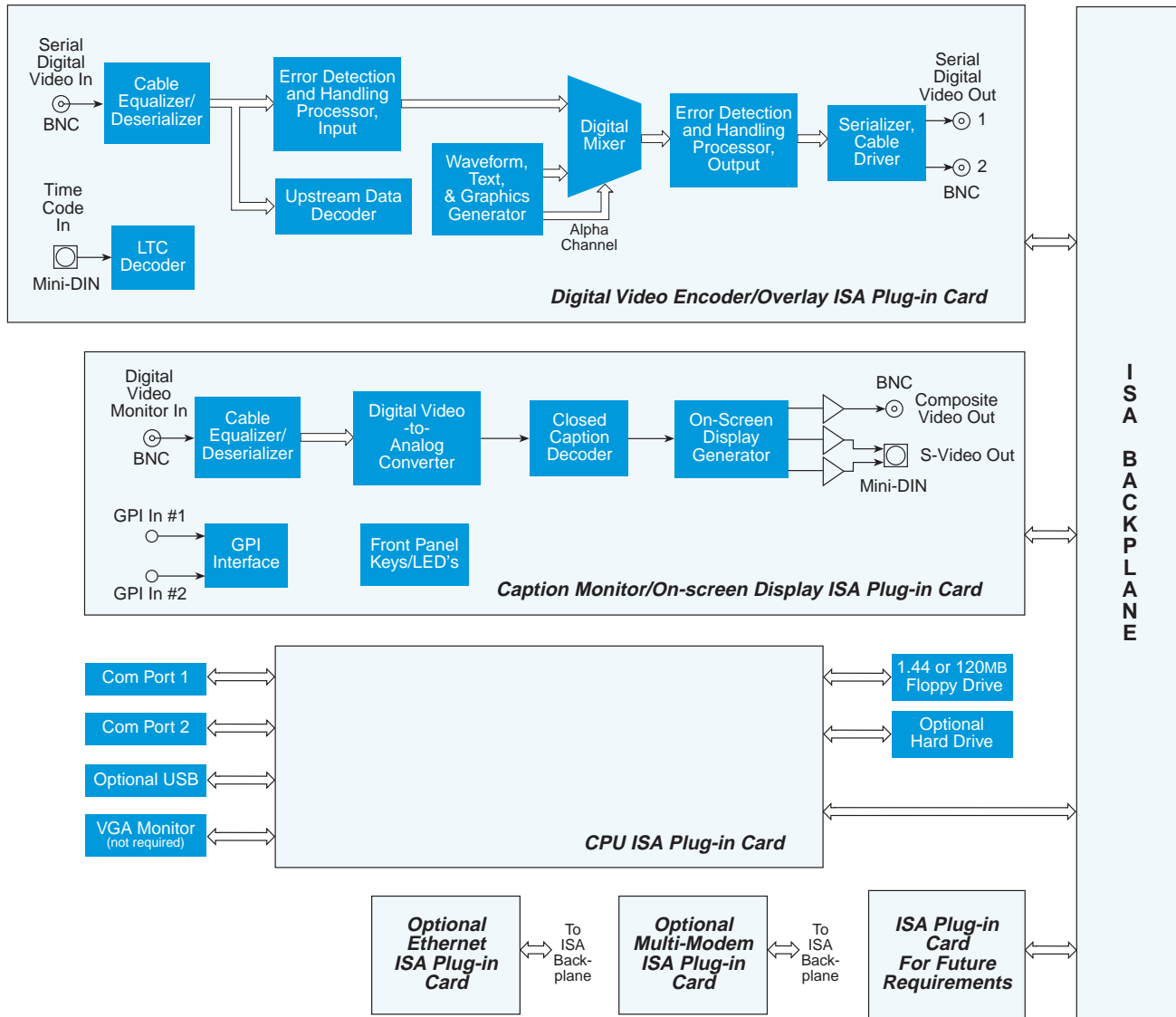

Fig. 6-1. Block diagram

6. Technical Reference

6.1 Calibration

Calibrating the DV2000 involves adjusting a single trimpot only. The pot sets the video output at the analog monitor output.

Test Equipment

Component digital video pattern generator

75 ohm BNC terminator, 1%

Waveform monitor or ULTECH TV Trigger Mate & 20 MHz oscilloscope

Procedure

- ❑ 1. Remove AC line cord. Remove (6) phillips screws from sides of top cover. Remove top cover.
- ❑ 2. Attach AC line cord. Turn unit on. Allow unit and test equipment to warm-up for 15 minutes. Caution: a shock hazard exists with the top cover removed. Do not touch AC line switch or AC wiring. Apply a stable 1Vpp stairstep pattern to Monitor Video In.
- ❑ 3. Adjust R22 trimpot located on the DigMon PC board for 1Vpp at Monitor Video Out when terminated into 75 ohm.

(end of procedure)

Fig. 6-2. Adjustments

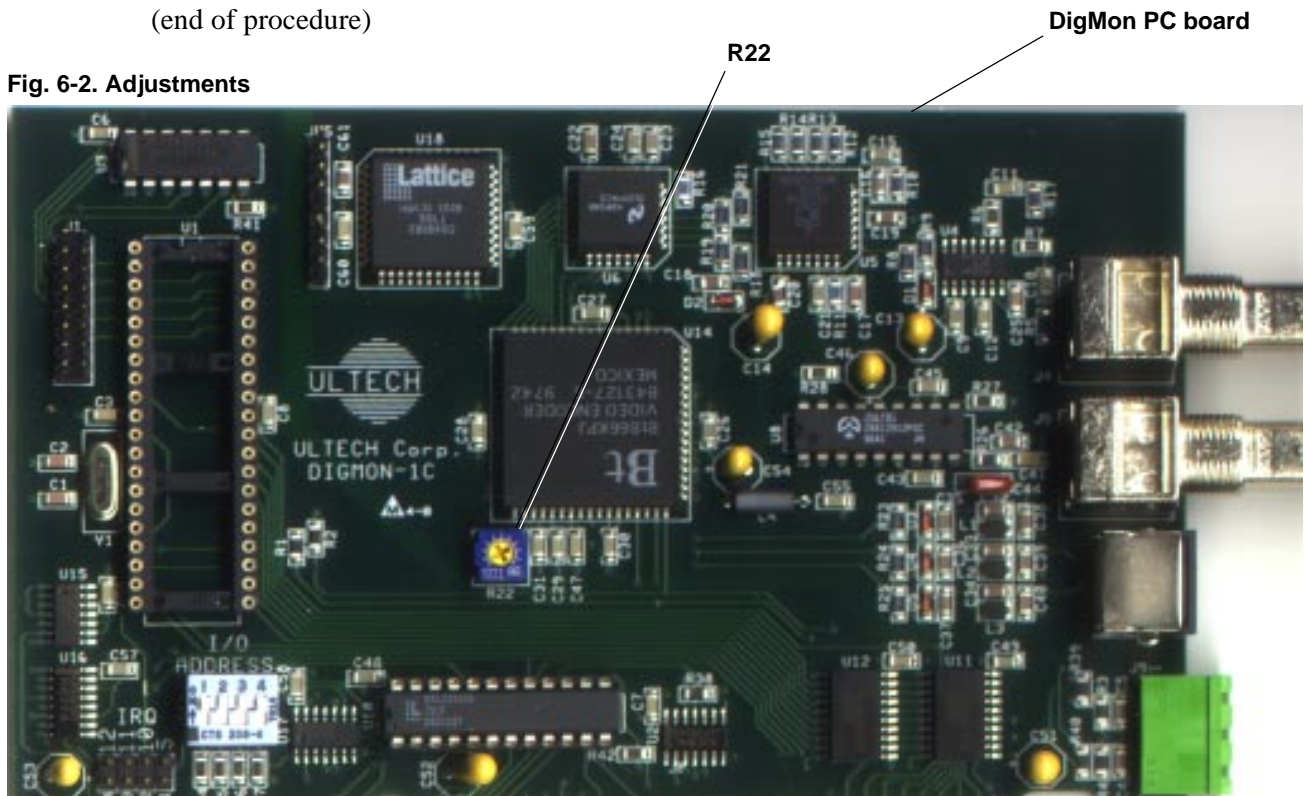

A shock hazard exists with the top cover removed—only qualified personnel should perform the calibration procedure.

6.2 Pinouts

GPI General Purpose Interface

<u>Pin</u>	<u>Function</u>
1	GPI Input/Output #1
2	Ground
3	GPI Input/Output #2

LTC Time Code

<u>Pin</u>	<u>Function</u>
1	Ground
2	Ground
3	Inverting Input (-)
4	Non-inverting Input (+)

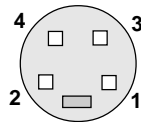

S-Video Output

<u>Pin</u>	<u>Function</u>
1	Ground
2	Ground
3	Y output
4	C output

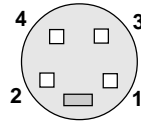

Com Ports

<u>Pin</u>	<u>Function</u>	<u>Notes</u>
1	Data Carrier Detect	(not used)
2	Receive Data	(input to DV2000)
3	Transmit Data	(output from DV2000)
4	Data Terminal Ready	(output from DV2000, not used)
5	Ground	
6	Data Set Ready	(input to DV2000, ignored)
7	Request To Send	(output from DV2000, not used)
8	Clear To Send	(input to DV2000, ignored)
9	Ring Indicator	(input to DV2000, ignored)

VGA

<u>Pin</u>	<u>Function</u>	<u>Pin</u>	<u>Function</u>
1	Red	9	(no connect)
2	Green	10	Ground
3	Blue	11	(no connect)
4	(no connect)	12	(no connect)
5	Ground	13	Hsync
6	Ground	14	Vsync
7	Ground	15	(no connect)
8	Ground		

Keyboard

<u>Pin</u>	<u>Function</u>
1	Keyboard Data
2	(no connect)
3	Ground
4	+5VDC
5	Keyboard Clock
6	(no connect)

Mouse

<u>Pin</u>	<u>Function</u>
1	MS Data
2	(no connect)
3	Ground
4	+5VDC
5	KBT1
6	(no connect)

6.3 Disk Contents

The current version of DV2000 runs under Microsoft DOS, so many of the files and directories on the DV2000 hard drive will appear familiar to you. Of course, you need to have the VGA monitor and a keyboard connected to the DV2000 in order to view and navigate around the DV2000 hard drive.

In addition to DOS, there is a subdirectory under the root called DV2000 (C:\DV2000). This directory contains four items: the DV2000 applications program (DV2000.exe), a hardware configuration file (hardware.cfg), a software configuration file (settings.cfg), and a subdirectory called "jobs" (C:\DV2000\Jobs). The "jobs" subdirectory contains all of the files associated with the jobs that are stored on your hard drive. A future version of DV2000 software will create a separate subdirectory under \jobs in which to store new jobs.

Hardware Configuration File (hardware.cfg)

Hardware.cfg stores information about the hardware that is unique to your DV2000. The DV2000 reads the contents of the file at start up. The file is an ASCII text file, and each line of the file must end with CR LF. If the file does not exist then the default values are assumed.

Line 1:	X.XX	Software version	(example "2.23")
Line 2:	XX	Revision of DigEnc Card	(Default = "1C")
Line 3:	XX	Revision of DigMon Card	(Default = "1C")
Line 4:	X	SuperDrive flag "0" = floppy, "1" = SuperDrive	(Default = "0")
Line 5:		Path for caption/subtitle server. Example: s:\CorpServer\CaptionFiles	

Your DV2000 must be equipped with the network option in order for line 5 to be processed.

Software Configuration File (settings.cfg)

Settings.cfg stores all of your current settings. The DV2000 software reads the contents of the file at start up. The file is an ASCII text file; each line of the file must end with CR LF. If the file does not exist then a default file will be created by the software.

Line 1:	X.XX	Software version	Example: "2.23"
Line 2:	XX	CC monitor setting:	"00" = off (Default = "01") "01" = CC1 "05" = T1 "02" = CC2 "06" = T2 "03" = CC3 "07" = T3 "04" = CC4 "08" = T4 "09" = XDS (Graze mode) "10" = XDS (Full mode)
Line 3:	xHH:MM:SS:FF (Default = "+00:00:00:00")	Time code offset:	x = sign ("+" or "-") HH = hours ("00" - "12") MM = minutes ("00" - "59") SS = seconds ("00" - "59") FF = frames ("00" - "30")
Line 4:	XXX	CC Level Low	("001" - "064") (Default = "016")
Line 5:	XXX	CC Level High	("096" - "144") (Default = "126")
Line 6:	XXX	CC Position	("001" - "050") (Default = "013")
Line 7:	XXXX	EDH Error Flag Mask	("0000" - "FFFF") (Default = "0000") (see EDH spec)

6.4 Specifications

Front panel controls & indicators

- Power on/off switch
- Reset button
- Program video LED
- Monitor video LED
- Data in LED
- Time code LED
- Hard disk LED
- Setup LED
- Floppy drive/LS-120 SuperDrive
- Cursor keys

Rear Panel controls & connectors

- IEC power output connector, rated 120 VAC at 3A Max or 240 VAC at 2A Max
- IEC power input connector for detachable three wire AC line cord
- 120 VAC/240 VAC line voltage selection switch
- PS-2-style keyboard connector, 4 pin mini-DIN
- PS-2-style mouse connector, 4 pin mini-DIN
- RS-232 serial interface connector, DB9M.
- VGA output connector, DB15F
- (1) 800 mVpp serial digital video input BNC, terminated into 75 ohm
- (2) 800 mVpp serial digital video output BNCs, with 75 ohm source impedance
- LTC time code input, balanced, +4dBu nominal input level, 4 pin mini-DIN
- 850 mVpp serial digital monitor video input BNC, terminated into 75 ohm
- 1Vpp monitor video output BNC, with 75 ohm source impedance
- Y/C monitor video output mini-DIN, with 75 ohm source impedance
- Dual GPI port, pluggable header, with internal 4.7K ohm pull-up to +5VDC

Power

- 150 Watt, 50/60 Hz
- 90 VAC to 135 VAC (120 VAC setting)
- 180 VAC to 265 VAC (240 VAC setting)

Enclosure

- Dimensions: 19" W (483) x 3.50" H (89) x 14.5" D (368)
- Front panel: 0.125" aluminum, painted
- Rear, tray, top: .042" steel, gold iridite
- Weight: 18 lbs. (8.2 kg.)

Specifications subject to change without notice